

KITZ SCT

PCVA Series

APC Butterfly Valve



KITZ
Group

VACUUM Series

Features

Auto PID Function provides the following controls:

- **Pressure control** : Adjusts pressure automatically to a specified target pressure.
- **Target change** : Responds to changes in target pressure value during pressure control.
- **Flow rate fluctuation** : Allows pressure control for flow rates other than the learned flow rate.
- **Disturbance effect** : Converges to target pressure regardless of flow rate changes during target pressure control.
- **Detection of misalignment** : Allows detection of misalignment caused by-product adhesion, mechanical part trouble, etc.

Structure

Appearance

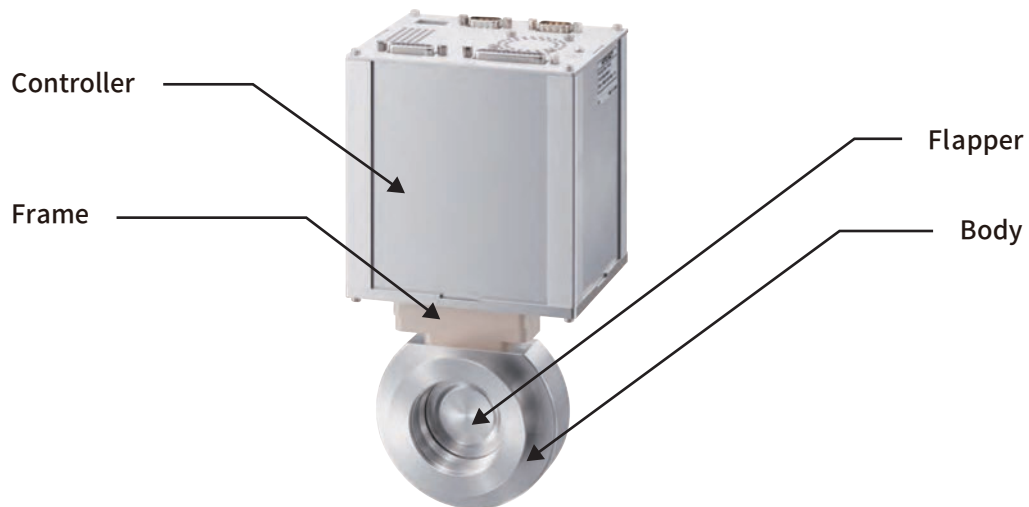

Interface

LOGIC, RS232C specification

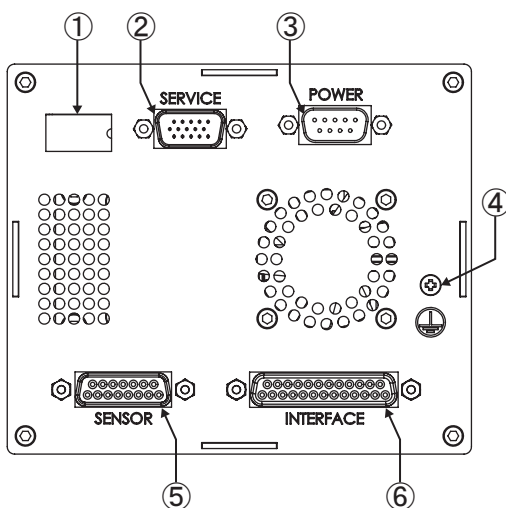

EtherCAT specification

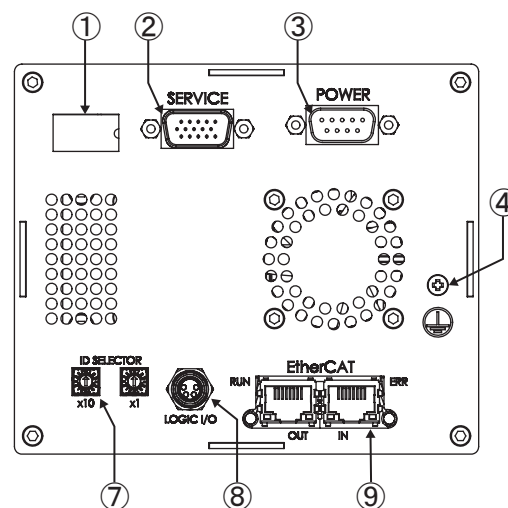

- ① Digital display
- ② PC connection
- ③ DC 24 V power connection
- ④ External ground connection
- ⑤ Pressure sensor connection
- ⑥ Logic/RS232C connection
- ⑦ ID selector
- ⑧ Logic connection
- ⑨ EtherCAT connection

Specifications

Items	Specifications	
Body Size	40A	50A
Conductance *1	64L/s	138L/s
Connection Flange	ISO-KF NW Flange	
Operating Pressure	1×10^{-6} Pa ~ 0.101MPa	
Leak Rates *2	Across the Seat He Leak Rates : 1×10^{-10} Pa·m ³ /s Inboard He Leak Rates : 1×10^{-9} Pa·m ³ /s	
Differential Pressure	14.6psi(0.101MPa)	
Response Time	Fully open ⇒ Fully close : 0.5s Fully close ⇒ Fully open : 0.5s	
Cycle Life *3	Fully open/close: 250,000 times Pressure regulation: 2 million times	
Atmospheric Temperature	5~50°C	
Body Allowable Temperature	120°C	
Standard Material	Body, Flapper, Stem : SUS316L Frame : PEEK Sealant (O ring) : FKM	
Weight	2.7kg	3kg

Items	Specifications
Pressure Control Accuracy	0.1% of sensor full scale
Opening Control Accuracy	0.1% of valve opening
Maximum Number of Pressure Sensors Connectable	2
Full Scale of Operating Pressure Sensor	13.3 Pa ~ 1.33×10^5 Pa (0.1Torr~1000Torr)
Power	LOGIC specification: DC24V±10% 3.2A max RS232C, EtherCAT specification : DC24V±10% 3.1A max
Network Interface	LOGIC, RS232C, EtherCAT

*1 Calculated value at flapper fully open, in molecular flow range, and at distance between valve surfaces

*2 Test conditions

Temperature : Normal temperature

Inspection time : 30 seconds

*3 Test conditions

Atmospheric release, set at 120°C

Dimensions

Unit: mm(inch)

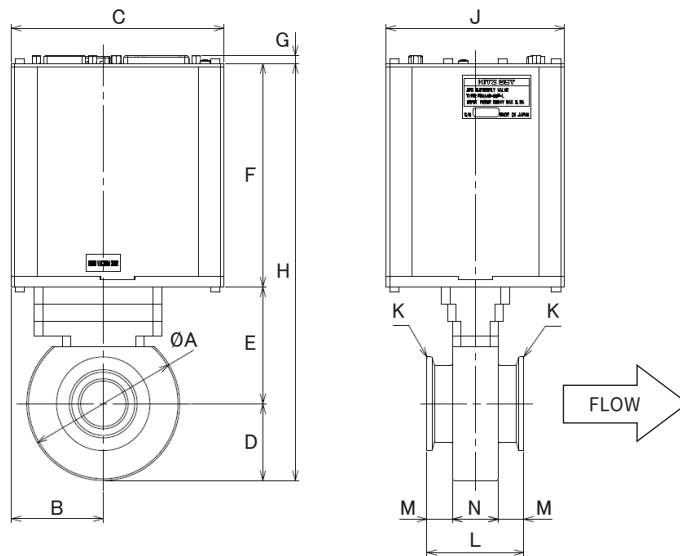

Size	40A	50A
A	90(3.543)	100(3.937)
B	54(2.126)	
C	125(4.921)	
D	45(1.772)	50(1.969)
E	68.5(2.697)	73(2.874)
F	131(5.157)	
G	LOGIC, RS232C specification : 4.8(0.189)* EtherCAT specification : 8(0.315)*	
H	244.5(9.626)	254(10.000)
J	105(4.134)	
K	KF40	KF50
L	57(2.244)	
M	15(0.591)	
N	27(1.063)	

* Connector dimension from top surface of controller.

Product Number

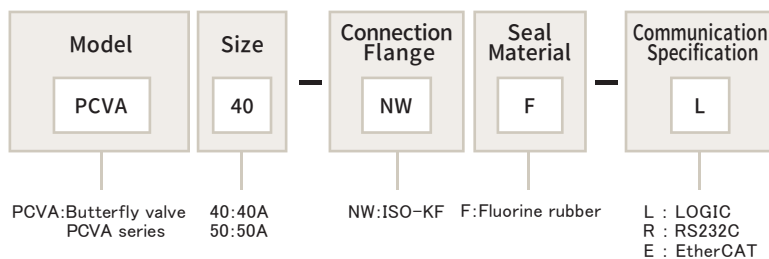

Options	Overview
INTERFACE cable 5.0m[16.4ft] (LOGIC)	Cable for connecting INTERFACE connector
INTERFACE cable 5.0m[16.4ft] (RS232C)	
SENSOR cable 5.0m[16.4ft]	Cable for connecting SENSOR connector
POWER cable 5.0m[16.4ft]	Cable for connecting POWER connector

*Contact us for options other than those listed above.



Caution

Product specifications and performance values described in this catalog are based on our design calculations, in-house testing, product usage performance and public standards and specifications, and are posted as a user's guide under general usage conditions of the product. If the product is used outside of the described usage conditions or under special usage conditions, you should receive our technical advice in advance or it will be necessary to first conduct research and evaluation for performance verification at the users' own responsibility. Even if physical or personal damage occurs without use of the procedure, we shall assume no responsibility. Although this catalog has been edited with the utmost care possible, contact us if there are any unclear points if you come across any questionable matter. In addition, information described in this catalog will be revised without notice due to reasons that include correction of errors, supplement/improvement of insufficient content, improvement in product performance design change, and discontinuation of production of products, etc., when deemed necessary. This invalidates the product catalog of the previous version. The issue code is described in the back of your catalog. For product selection, contact us to confirm whether your catalog is the latest version. In addition, when exporting our products, exporters should obtain an export permit from the Ministry of Economy, Trade and Industry based on the provisions of the Export Trade Control Order of the "Foreign Exchange and Foreign Trade Act." Contact us regarding any unclear points.

■ Sales Office

KITZ SCT HEADQUARTERS : +81-3-6404-2171
KITZ SCT AMERICA CORPORATION : +1-408-747-5546
KITZ SCT CORPORATION TAIWAN
REPRESENTATIVE OFFICE : +886-3-542-0110
KITZ SCT CORPORATION OF KUNSHAN,
SHANGHAI BRANCH COMPANY : +86-21-5243-5025

■ Factory

KITZ SCT CORPORATION OF KUNSHAN : +86-512-5735-0700

For information on our locations, please visit the following website.



KITZ SCT corporation Headquarters
Tokyo Shiodome Building, 1-9-1, Higashi-Shimbashi, Minato-ku,
Tokyo 105-7305, Japan
<https://en.kitzsct.com/>



WebSite